

# RP501R

## Owner's Manual

### Contents

|  |           |  |           |
|--|-----------|--|-----------|
| <b>Operation Guide</b> .....   | <b>2</b>  | Specifying How the Bass Part Behaves (Leading Bass).....                     | <b>12</b> |
| Performing .....   | <b>2</b>  | Chord Recognition When Split Is On.....                                      | <b>12</b> |
| Playing Back Songs .....   | <b>4</b>  | Preventing Doubled Notes When Connected to a Sequencer (Local Control) ..... | <b>12</b> |
| Using Automatic Accompaniment (Rhythm) That Matches Your Chords .....                      | <b>5</b>  | Copying a Song (Copy Song).....  | <b>12</b> |
| Recording Performances .....   | <b>6</b>  | <b>Bluetooth</b> Function.....   | <b>12</b> |
| Playing Songs from a USB Flash Drive (Sold Separately).....                                | <b>7</b>  | <b>Bluetooth</b> Page-Turning/MIDI Switching .....                           | <b>12</b> |
| <b>Panel Descriptions</b> .....  | <b>8</b>  | <b>Bluetooth</b> Page-Turning Pedal Assignment.....                          | <b>12</b> |
| Front Panel.....   | <b>8</b>  | Making the Power Automatically Turn Off After a Time (Auto Off) .....        | <b>13</b> |
| Rear Panel Connections .....   | <b>9</b>  | Saving the Settings (Memory Backup) .....                                    | <b>13</b> |
| Bottom Panel (Connecting Headphones or Memory) .....                                       | <b>9</b>  | <b>Restoring the Factory Settings (Factory Reset)</b> .....                  | <b>13</b> |
| <b>Before You Play</b> .....   | <b>10</b> | <b>Specifying the Maximum Volume (Volume Limit)</b> .....                    | <b>13</b> |
| Opening/Closing the Lid .....  | <b>10</b> | <b>Using the Bluetooth® Functionality</b> .....                              | <b>14</b> |
| Turning the Power On/Off .....   | <b>10</b> | Here's What You Can Do .....   | <b>14</b> |
| Setting the Reference Pitch.....   | <b>10</b> | Using the Pedal to Turn Pages on a Music Score App .....                     | <b>14</b> |
| <b>Various Settings (Function Mode)</b> .....  | <b>11</b> | Connecting an Already-Paired Mobile Device .....                             | <b>14</b> |
| Basic Operation in Function Mode .....   | <b>11</b> | Changing the Operating Keys of the Page Turning Function                     | <b>15</b> |
| Adjusting the Keyboard Sensitivity (Key Touch) .....                                       | <b>11</b> | Transferring MIDI Data .....   | <b>15</b> |
| Changing the Way in Which the Sound Is Heard (Twin Piano Mode) .....                       | <b>11</b> | Problems with <b>Bluetooth</b> Functionality .....                           | <b>15</b> |
| Dividing the Keyboard for Two-Person Performance (Twin Piano) .....                        | <b>11</b> | <b>Troubleshooting</b> .....   | <b>16</b> |
| Specifying What the Transpose Will Affect (Transpose Mode).....                            | <b>11</b> | <b>Message List</b> .....  | <b>17</b> |
| Transposing the Keyboard or Song (Transpose) .....   | <b>11</b> | <b>USING THE UNIT SAFELY</b> .....   | <b>18</b> |
| Applying a Headphones 3D Ambience Effect to the Piano Sound (Headphones 3D Ambience) ..... | <b>11</b> | <b>IMPORTANT NOTES</b> .....   | <b>18</b> |
| Matching the Pitch with Other Instruments (Master Tuning)                                  | <b>11</b> |  |           |
| Changing the Tuning Method (Stretch Tuning) .....  | <b>12</b> |  |           |
| Changing How the Pedals Work.....  | <b>12</b> |  |           |

### Main Specifications Roland RP501R: Digital Piano

|                          |   |
|--------------------------|---|
| <b>Keyboard</b>          | 88 keys (PHA-4 Standard Keyboard: with Escapement and Ivory Feel)   |
| <b>Sound Generator</b>   | Piano Sound: SuperNATURAL Piano Sound<br>MIDI Format: Conforms to GM2/GS/XGlite   |
| <b>Bluetooth</b>         | MIDI, Turning music sheet: <b>Bluetooth</b> Ver 4.0 (Only on <b>Bluetooth</b> -equipped models)   |
| <b>Power Supply</b>      | AC adaptor  |
| <b>Power Consumption</b> | 9 W (3 W–22 W)<br>9 W: Average power consumption while piano is played with volume at center position<br>3 W: Power consumption immediately after power-up; nothing being played<br>22 W: Rated power consumption |

|                                     |   |
|-------------------------------------|---|
| <b>Dimensions (with music rest)</b> | 1,378 (W) x 423 (D) x 992 (H) mm<br>54-1/4 (W) x 16-11/16 (D) x 39-1/16 (H) inches  |
| <b>Weight</b>                       | 40.8 kg / 90 lbs  |
| <b>Accessories</b>                  | Owner's manual, Leaflet "Assembling the Piano," Leaflet "USING THE UNIT SAFELY," AC adaptor, Power cord (for connecting AC adaptor), Headphone Hook, Music Rest   |
| <b>Options (Sold Separately)</b>    | USB Flash Memory<br>* Use a commercially available USB flash drive or a USB flash drive sold by Roland. However, we cannot guarantee that all commercially available USB flash drives will work with this unit. |

\* This document explains the specifications of the product at the time that the document was issued. For the latest information, refer to the Roland website.

### Provision of **Bluetooth** functionality

Please be aware that depending on the country in which you purchased the unit, **Bluetooth** functionality might not be included.

#### If **Bluetooth** functionality is included



Before using this unit, carefully read the sections entitled "USING THE UNIT SAFELY" and "IMPORTANT NOTES" (leaflet "USING THE UNIT SAFELY" and Owner's Manual p. 18). After reading, keep the document(s) where it will be available for immediate reference.

## Performing

### Selecting Tones ([Piano] [Other] Buttons)

This digital piano lets you enjoy playing a variety of piano tones (sounds) and other types of tones.

You can select a tone and adjust the way that it sounds.

|   |  |
|---|--|
| <b>Selecting a piano tone</b>                             | Press the [Piano] button.  |
| <b>Selecting other tones</b>                              | Press the [Other] button.  |
| <b>Selecting various tones</b>                            | Press the [Piano] or [Other] button, and then press the [-] [+].   |
| <b>Adjusting the spaciousness of the sound (Ambience)</b> | Hold down the [Piano] button and press the [-] [+].<br>* If you're using headphones and the Headphones 3D Ambience effect (p. 11) is set to "On," this lets you adjust the depth of the Headphones 3D Ambience effect. |
| <b>Adjusting the brightness of the sound (Brilliance)</b> | Hold down the [Other] button and press the [-] [+].  |

#### [Piano] button

| Display | Explanation   |
|---------|---|
|         | <b>Concert Piano</b><br>The sound of a splendid concert grand piano. This piano sound has our highest recommendation, and can be used for any style of music. |

| Display | Explanation  |
|---------|--|
|         | <b>Ballade Piano</b><br>A mellow grand piano sound, recommended for quiet songs.                                       |
|         | <b>Bright Piano</b><br>A brilliant grand piano sound, recommended when you want the piano to stand out in an ensemble. |
|         | <b>Magical Piano</b><br>A charming sound that layers synth bells with Concert Piano.                                   |
|         | <b>Piano+Strings</b><br>Strings layered with Concert Piano.  |
|         | <b>Piano+Pad</b><br>A pad layered with Concert Piano.  |
|         | <b>Piano+Choir</b><br>A choir layered with Concert Piano.  |
|         | <b>Rock Piano</b><br>A robust piano sound, recommended for boogie-woogie playing.                                      |
|         | <b>Ragtime Piano</b><br>A honky-tonk piano sound, recommended for ragtime playing.                                     |
|         | <b>Harpsichord</b><br>A type of keyboard instrument widely used in Baroque music, producing a delicate sound.          |
|         | <b>Coupled 8+4</b><br>The sound of a harpsichord layered with sound an higher octave.                                  |



### Playing Different Tones with the Right and Left Hands ([Split] Button)

You can play different tones in the left and right sides of the keyboard, divided at a certain key.

This feature is called "Split Play," and the key at which the keyboard is divided is called the "Split Point."

|  |  |
|--|--|
| <b>Turning the split feature on</b>        | Press the [Split] button so it's lit.  |
| <b>Changing the keyboard's split point</b> | Hold down the [Split] button and press the key at the desired split point.     |
| <b>Changing the Right-Hand Tone</b>        | Same as "Selecting Tones."   |
| <b>Changing the Left-Hand Tone</b>         | Hold down the [Split] button and use the steps described in "Selecting Tones." |

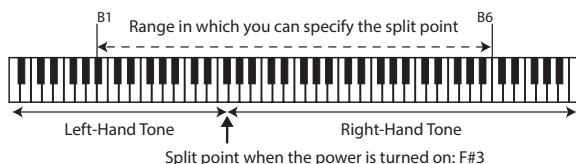

\* The split point is the highest note of the left-hand tone.

| Display (example) | Pitch |
|-------------------|-------|
|                   | F#3   |
|                   | A#4   |
|                   | C4    |

#### MEMO

Separate, independent settings for Split can be made for the Song mode (p. 4) and the Rhythm mode (p. 5).

### Layering Two Tones (Dual Play)

You can play two tones simultaneously from each note of the keyboard. This feature is called "Dual Play."

|                         |   |
|-------------------------|---|
| <b>Turning Dual on</b>  | Hold down the [Piano] button and press the [Other] button.                      |
| <b>Turning Dual off</b> | Press the [Piano] or the [Other] button.  |
| <b>Selecting tones</b>  | Select tones for the [Piano] button and [Other] button before you turn Dual on. |

1. Press the [Piano] button, and then use the [-] [+].
2. Press the [Other] button, and then use the [-] [+].
3. Hold down the [Piano] button and press the [Other] button to turn Dual on.

Tone 1 and tone 2 are heard together.

To turn Dual off, press the [Piano] button or the [Other] button.

### Changing the Key (Transpose)

The Transpose function lets you shift the pitch of the keyboard in semitone steps. You can use this to play the song in a different key.

For details, refer to "Transposing the Keyboard or Song (Transpose)" (p. 11).

## Using the Metronome ([Metronome] Button)

You can perform while the metronome sounds. You can adjust the tempo or beat of the metronome.  
If a song is playing, the metronome will sound at the tempo and beat of that song.



|                                      |  |
|--------------------------------------|--|
| <b>Using the Metronome</b>           | Press the [Metronome] button so it blinks.   |
| <b>Changing the Tempo</b>            | Turn on the [Metronome] button to display the tempo, and then use the [-] [+] buttons.<br>   |
| <b>Changing the Beat</b>             | Hold down the [Metronome] button and press the [-] [+] buttons.<br><br>For details on the available time signatures, refer to "List of Time Signatures." |
| <b>Adding a count-in</b>             | Turn on the metronome, and then press the [▶/■] (Start/Stop) button.   |
| <b>Changing the metronome volume</b> | Hold down the [Metronome] button and use the Volume buttons.<br><br>Soft Loud  |

## List of Time Signatures

| Display | Beat                             | Display | Beat |
|---------|----------------------------------|---------|------|
|         | 2/2                              |         | 6/4  |
|         | Only weak beats will be sounded. |         | 7/4  |
|         | 2/4                              |         | 3/8  |
|         | 3/4                              |         | 6/8  |
|         | 4/4 (default)                    |         | 9/8  |
|         | 5/4                              |         | 12/8 |



## Adjusting the Keyboard Sensitivity (Key Touch)

Here's how to change the way in which the sound responds to your keyboard dynamics. You can adjust the response as appropriate for your playing strength.

1. Hold down the [Metronome] button and press the [Split] button.
2. Use the [-] [+] buttons to choose "F 1" and press the [▶/■] button.
3. Use the [-] [+] buttons to change the settings.

| Value             | Explanation   |
|-------------------|---|
| F (Fixed)         | The sound plays at one set volume, regardless of the force used to play the keys.   |
| L 2 (Super Light) | An even lighter setting than L 1 (Light).   |
| L 1 (Light)       | Sets the keyboard to a light touch. You can achieve fortissimo (ff) play with a less forceful touch than "M (medium)," so the keyboard feels lighter. This setting makes it easy to play, even for children.                            |
| M (Medium)        | Sets the keyboard to the standard touch. This sets the standard keyboard touch. You can play with the most natural touch. This is the closest to the touch of an acoustic piano.  |
| H 1 (Heavy)       | Sets the keyboard to a heavy touch. You have to finger the keyboard more forcefully than "M (medium)" in order to play fortissimo (ff), so the keyboard touch feels heavier. Dynamic fingering adds even more feeling to what you play. |
| H 2 (Super Heavy) | An even heavier setting than H 1 (Heavy).   |

4. Hold down the [Metronome] button and press the [Split] button to exit Function mode.

## Dividing the Keyboard in Two (Twin Piano)

You can divide the keyboard into left and right sections so that two people can play the same pitch ranges.

1. Hold down the [Metronome] button and press the [Split] button.
2. Use the [-] [+] buttons to choose "F 2" and press the [▶/■] button.
3. Choose the "2" setting.  
\* Concert Piano is selected.
4. Hold down the [Metronome] button and press the [Split] button to exit Function mode.

**Changing how Twin Piano sounds**

In function mode, select "F 2" and choose "1" or "2"

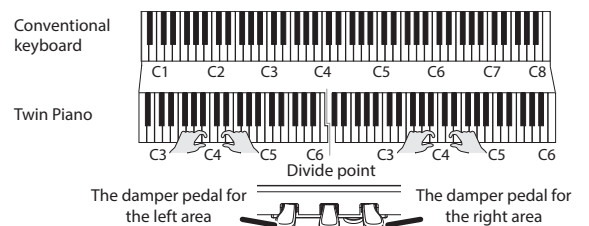

- 1 → Notes in the right section are louder in the right speaker; notes in the left section are louder in the left speaker.
- 2 → Notes in the right section are heard only from the right speaker; notes in the left section are heard only from the left speaker.





## Playing Back Songs

### How to Use Song Mode ([Song] Button)

Press the [Song] button to select Song mode.

| Selecting a Song   | <p>Press the [Song] button, and then use the [-] [+] buttons.<br/>In the middle of a song, pressing the [-] button will return you to the beginning of the song.</p> <table border="1"> <thead> <tr> <th>Recorded songs</th> <th>Internal songs</th> </tr> </thead> <tbody> <tr> <td>n.01 - U.10</td> <td>d.01 - d.36</td> </tr> </tbody> </table>  <ul style="list-style-type: none"> <li>• Songs indicated by "d, b, c, d" are internal songs. For details, refer to "Internal Song List" at the end of this manual.</li> <li>• Songs indicated by "U" are songs that were recorded in internal memory.</li> <li>• Songs indicated by "n" are songs that were recorded on a USB flash drive.</li> <li>* To switch between categories "d, b, c, d, U, n," hold down the [Song] button and press the [-][+] buttons.</li> </ul> | Recorded songs | Internal songs | n.01 - U.10 | d.01 - d.36 |
|--|--|----------------|----------------|-------------|-------------|
|  | Recorded songs   | Internal songs |                |             |             |
| n.01 - U.10  | d.01 - d.36  |                |                |             |             |
| <p>Changing the number of measures in a song</p>  <p>Use the [◀◀] [▶▶] buttons to specify the number of measures.</p> |  |                |                |             |             |

|                                 |   |
|---------------------------------|---|
| Changing the Tempo              | <p>Press the [Metronome] button.<br/>Use the [-] [+] buttons to change the tempo.</p>   |
| Changing the Volume of the Song | <p>Hold down the [Song] button and use the Volume buttons to adjust the volume of the song.</p> <p>Song volume – Manual performance volume</p>  <p>(Song is louder) (Same loudness) (Manual performance is louder)</p> |
| Playing all songs               | <p>Hold down the [Song] button and press the [▶/■] button (All Song Play).</p>  |

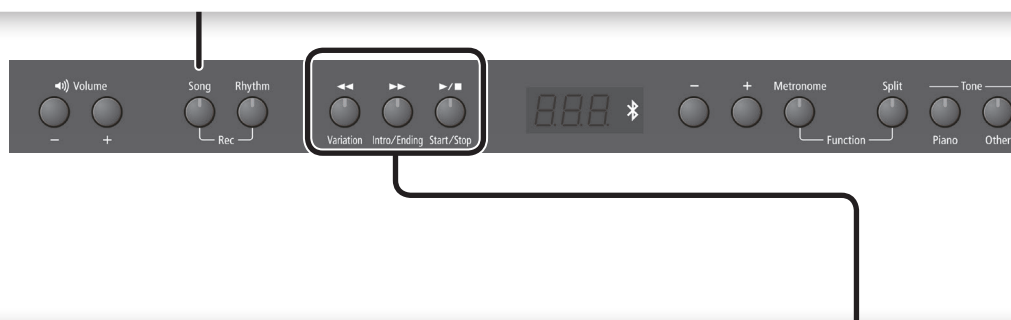

### Functions of the [◀◀] [▶▶] [▶/■] Buttons

|                                 |  |
|---------------------------------|--|
| Starting/Stopping Song Playback | <p>Press the [▶/■] button.<br/>When the song has finished playing to the end, it will stop.</p>                                    |
| Fast-Forward                    | <p>Press the [▶▶] button.<br/>By holding down the [▶▶] button and pressing the [◀◀] button, you can fast-forward more quickly.</p> |
| Rewind                          | <p>Press the [◀◀] button.<br/>By holding down the [◀◀] button and pressing the [▶▶] button, you can rewind more quickly.</p>       |

#### Selecting Parts to Play

#### 1. Hold down the [▶/■] button and use the [-] [+] buttons to select the parts to be played.

Through successive presses of these buttons, you can turn on or off the accompaniment part, left-hand part, and right-hand part to achieve the desired arrangement of played/muted parts.

#### Playback part play/mute status indication

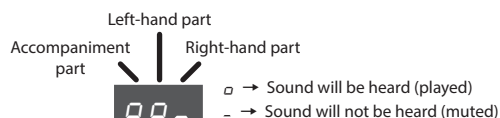

- \* When using Twin Piano, what you play in the left section is recorded to the left-hand part, and what you play in the right section is recorded to the right-hand part.
- \* When using Split, the left-hand tone is recorded to the left-hand part, and the right-hand tone is recorded to the right-hand part.
- \* When using Dual, tone 1 is recorded to the right-hand part and tone 2 is recorded to the accompaniment part.
- \* When playing anything other than Twin Piano, Split, or Dual, everything is recorded on the right-hand part.

# Using Automatic Accompaniment (Rhythm) That Matches Your Chords

## How to Use Rhythm Mode ([Rhythm] Button)

Press the [Rhythm] button to select Rhythm mode.

Split is turned on.

While the rhythm is playing, the left-hand part will not sound, since that section is dedicated to the recognition of chords.

|  |   |
|--|---|
| <b>Selecting a Rhythm</b>                | Press the [Rhythm] button, and then use the [-] [+] buttons.<br><b>1-1-9-6</b><br>For details, refer to "Rhythm List" at the end of this manual.<br>* To switch the genre of rhythm, hold down the [Rhythm] button and press the [-] [+] buttons. |
| <b>Changing the Tempo</b>                | Press the [Metronome] button.<br>Use the [-] [+] buttons to set the tempo.<br><b>108</b><br>Tempo range <b>20 - 250</b>   |
| <b>Changing the Volume of the Rhythm</b> | Hold down the [Rhythm] button and use the Volume buttons to adjust the volume of the rhythm.<br>Rhythm volume - Manual performance volume<br><b>91 - 99 - 19</b><br>(Rhythm is louder) (Same volume) (Manual performance is louder)               |

### About the rhythm function

This unit contains many built-in rhythms in various musical styles, such as jazz and rock.

Rhythms include not only drum sounds, but also accompaniments featuring instruments such as piano, guitar, bass, and strings.

You can also add intros and endings to your rhythms, and insert fill-ins. These features make it easy to develop effective and expressive rhythmic accompaniment.

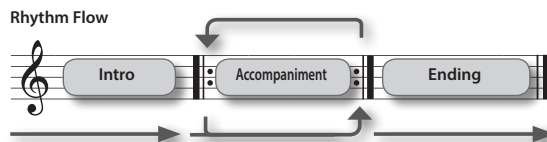

There are two types of rhythms: original accompaniment patterns, and variation accompaniment patterns, which embellish the original patterns.

It can be effective to use the quieter original patterns in the first half of the song, and then use the variation patterns in the latter half, when you want to build excitement.

### How to play chords

When a chord is played on the keyboard, a rhythm based on the chord that was played is sounded. (When the keys marked with "●" in the illustration are played, the result is recognized as "C.")



Note that it is not necessary to press all of the constituent notes of the chord; chords can be specified using simple fingering. (When the key marked with "★" in the illustration is played, it is recognized as "C.")

For details, refer to "Chord Recognition When Split Is On" (p. 12), and the "Chord Fingering List" at the rear of this manual.



## What the [◀◀ (Variation)] [▶▶ (Intro/Ending)] [▶/■ (Start/Stop)] Buttons Do

|   |   |
|---|---|
| <b>Starting/Stopping the Rhythm</b>                               | Press the [▶/■ (Start/Stop)] button.  |
| <b>Adding an Intro</b>  | Turn on the [▶▶ (Intro/Ending)] button, and then play the rhythm.   |
| <b>Adding an Ending</b>   | While the rhythm is playing, turn on the [▶▶ (Intro/Ending)] button.<br>An ending is played, and then playback stops.   |
| <b>Adding Variation to the Rhythm</b>                             | Press the [◀◀ (Variation)] button.<br>Off → A simple accompaniment pattern is played.<br>On → A more flamboyant accompaniment pattern is played.  |
| <b>Inserting a Fill-in When You Switch Variations (Auto Fill)</b> | While holding down the [◀◀ (Variation)] button, use the [-] [+] buttons to select "On," and then switch variations.<br><b>What's a "Fill-In?"</b><br>A short improvisational phrase inserted at the transition is called a "Fill-In." |
| <b>Starting the Rhythm by Playing a Key (Sync)</b>                | Press the [Rhythm] button.<br>The rhythm starts playing when you play the keyboard.<br><b>5nc</b>   |

### Playing Only the Drums or Another Specific Part

1. While holding down the [▶/■ (Start/Stop)] buttons, use the [-] [+] buttons to select the mute setting.

Through successive presses of these buttons, you can turn on or off the drums, bass, and other instruments to achieve the desired arrangement of played/muted parts.

#### Play/mute status indication for the rhythm parts

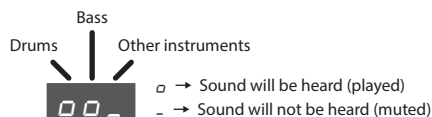

#### NOTE

For some rhythms, you'll hear other instruments even in the bass part.

## Recording Performances



You can record your performance, including accompaniment.

You can play back a recorded performance to check your playing, or to play along with it.

### Getting Ready to Record

1. Select the tone that you want to play on the keyboard (p. 2).
2. Start the metronome if desired.

Press the [Metronome] button.

While the metronome is sounding, specify the tempo and time signature of the song (p. 3).

#### If you want rhythm to play

3. If you want a rhythm accompaniment to be heard while you perform, press the [Rhythm] button.

Specify the rhythm and tempo settings (p. 5).

#### If you don't want rhythm to play

3. Press the [Song] button so the button is lit.

### Entering Recording-standby Mode

4. Hold down the [Song] button and press the [Rhythm] button.

The [Song] button and the [Rhythm] button will light; the unit will enter recording-standby mode.

#### MEMO

If you decide not to record (i.e., if you want to exit recording-standby mode), hold down the [Song] button once again and press the [Rhythm] button.

### Starting Recording

5. Press the [Start/Stop] button.

A two-measure count will sound, and then recording will start.

During the count, measure numbers " - 2" and then " - 1" will appear in the display.

#### MEMO

Recording will start automatically if you play the keyboard while in recording-standby mode.

### Stopping Recording

6. Press the [Start/Stop] button.

By pressing the [Start/Stop] button once again, you can hear the song that you just recorded.

### Selecting the Destination of the Save

7. Use the [-] [+] buttons to select the destination at which to save, and then press the [Metronome] button.

U (User) U.0 1-U. 10

n (USB) n.0 1-n.99



A song with no recorded data (empty song)

- Song number shown with lowercase "u" (User memory)
- Song number shown with lowercase "n" (USB flash drive)
- No dot shown



A song with recorded data

- Song number shown with uppercase "U" (User memory)
- Song number shown with uppercase "n" (USB flash drive)
- Dot shown

#### MEMO

If you decide not to carry out the save, hold down the [Song] button and press the [Rhythm] button to cancel it.

#### NOTE

If you select a song that already contains data (song number with an uppercase "U" or "n") and save, the previously recorded data will be lost.

\* While the song is being saved, an animation of a rotating "d" symbol will appear in the display for several seconds. **Do not turn off the power during this time. Doing so might cause the saved song to be lost.**

## If you want to erase the recorded song

You can erase a song by recording an empty song as follows.

1. Press the [Song] button.
2. Hold down the [Song] button and press the [Rhythm] button.
3. Press the [Start/Stop] button to hear the two-measure count, and then press the [Start/Stop] button without playing the keyboard.
4. Select the song number that you want to erase, and press the [Metronome] button.

A song containing no notes will be recorded; the song has been erased.

## Playing Songs from a USB Flash Drive (Sold Separately)

### Connecting a USB Flash Drive

#### NOTE

- If the USB flash drive contains a large number of song files, it may take some time for the data to be read.
- Use only single-byte alphanumeric characters in the file names.

### 1. Using your computer, copy your favorite songs onto your USB flash drive (sold separately).

This digital piano is able to play back SMFs (Standard MIDI Files) or audio files (WAV) from a USB flash drive.

#### Playable formats

| Type | Explanation                         |
|------|-------------------------------------|
| SMF  | Standard MIDI files (format 0, 1)   |
| WAV  | WAV format, 44.1 kHz, 16-bit linear |

### 2. Connect your USB flash drive to the USB MEMORY port of the digital piano.

### Playing Songs

1. Press the [Song] button.
2. Use the [-] [+] buttons to select a song.

#### MEMO

- If you've selected an audio file (WAV file), a dot is displayed following the last digit.

The files on the USB flash drive are shown. "7" indicates a USB flash drive. The numbers are assigned automatically. If you later add or delete a file, the numbers will be automatically reassigned.

- All files on the USB flash drive begin with "7."
- If you use the [-] [+] buttons to make the display indicate "U" or "D," files in the digital piano's internal memory are displayed.

### 3. Press the [▶/■] button to play the selected song.

The display shows the measure number of the currently playing SMF. If a WAV file is playing, the elapsed playback time is shown.

(Example: 1 minute 1 second has elapsed)

### Lower the Level of an Audio File's Central Sound

This feature lets you reduce the loudness of the central sound of the audio (Center Cancel).

1. When a song is selected, hold down the [▶/■] button and use the [-] [+] buttons to turn this feature "On."

#### NOTE

This feature does not work perfectly with every song. In some cases it may be unable to fully eliminate the central sound, or may alter the recording's tone quality.

## About USB Flash Drives

If you're using a newly purchased USB flash drive, you must first format it on the digital piano.

#### NOTE

- Never insert or remove a USB flash drive while this unit is turned on. Doing so may corrupt the unit's data or the data on the USB flash drives.
- Use a commercially available USB flash drive or a USB flash drive sold by Roland. However, we cannot guarantee that all commercially available USB flash drives will work with this unit.

## Formatting a USB Flash Drive

Here's how to initialize (format) the entire contents saved on a USB flash drive.

#### NOTE

- Formatting will erase everything that has been saved on the USB flash drive.
- Before using a new USB flash drive with this digital piano for the first time, you must format the USB flash drive.

### 1. Connect the USB flash drive that you want to format to the USB MEMORY port.

### 2. While holding down the [Song] button, turn the power on.

Keep holding down the [Song] button until it indicates as "Sur" on the display.

To cancel, press the [▶] button.

### 3. To execute the format, press the [▶/■] button.

When all the LEDs on the buttons are lit, the operation is complete.

### 4. Turn the power off, then on again.

Bottom panel of digital piano

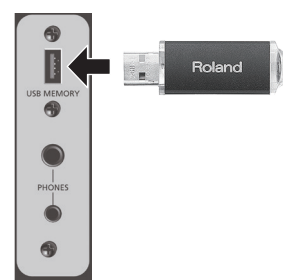

## Front Panel

### Adjusting the Volume and Balance (Volume Buttons)

#### Overall Volume

Use the Volume buttons to adjust the volume.

#### Volume Balance Between Song/Rhythm and the Keyboard (Song Balance) **M**

While holding down the [Song] button or [Rhythm] button, use the Volume buttons to adjust the balance.

Volume of the song – Volume of the manual performance  
**91 - 99 - 19**  
 (Song is louder) (Same volume) (Manual performance is louder)

#### Relative Balance of Dual Tones (Dual Balance) **M**

This is available if Dual is on. While holding down the [Piano] button and [Other] button, use the Volume buttons to adjust the balance.

Volume of the piano sound – Volume of the other sound  
**91 - 99 - 19**  
 (Piano is louder) (Same volume) (Other is louder)

#### Relative Balance of Split Tones (Split Balance) **M**

This is available if Split is on. Hold down the [Split] button and use the Volume buttons to adjust the balance.

Left-hand volume – Right-hand volume  
**91 - 99 - 19**  
 (Left-hand is louder) (Same volume) (Right-hand is louder)

### About the Display

This indicates the tone number, song number, measure number, tempo, selected function, or value.

|                |       |            |                 |               |             |
|----------------|-------|------------|-----------------|---------------|-------------|
| Tone number    | Piano | <b>1</b>   | Song number     | Internal song | <b>2.01</b> |
|                | Other | <b>1</b>   |                 | User          | <b>4.01</b> |
| Tempo          |       | <b>108</b> | USB flash Drive | <b>0.01</b>   |             |
| Measure number |       | <b>1</b>   | Rhythm          | <b>1-1</b>    |             |



\* For details on how to use the other buttons, refer to "Operation Guide" (p. 2)–(p. 7).

### [⏻] Switch

This turns the power on/off (p. 10).

**With the factory settings, the unit's power will automatically be switched off 30 minutes after you stop playing or operating the unit.**

If the unit's power has been turned off automatically, you can use the [⏻] switch to turn the unit back on again. If you don't want the power to turn off automatically, change the "Auto Off" setting to "OFF" as described on "Making the Power Automatically Turn Off After a Time (Auto Off)" (p. 13).



### Headphone Hook

Whenever you are not using the headphones, you can hang them on the headphone hook.

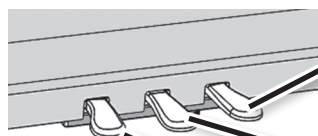
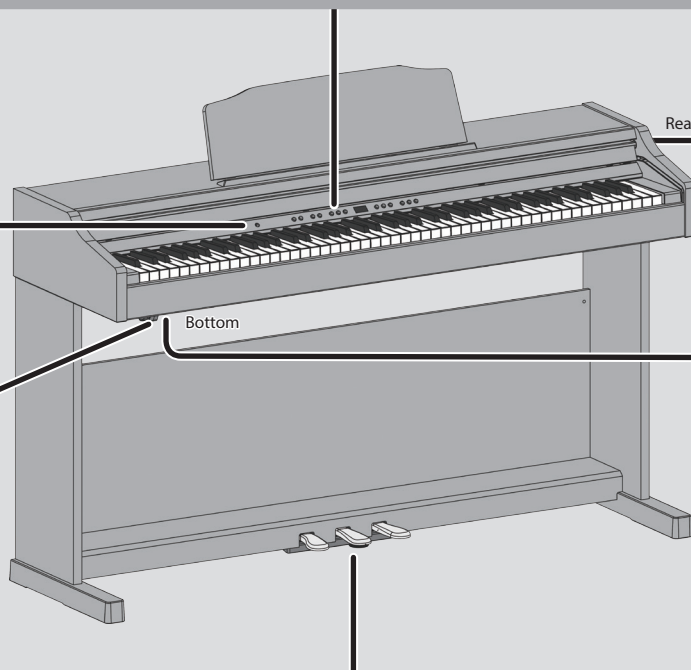

### Damper pedal

Use this pedal to sustain the sound. While this pedal is held down, notes will be sustained for an extended time even if you release your fingers from the keyboard. The length of the sustain will change subtly depending on how deeply you press the pedal. On an acoustic piano, holding down the damper pedal will cause the strings for notes other than the ones you actually play to vibrate in sympathy with what you've played, producing a rich resonance. This unit simulates this sympathetic vibration (damper resonance).

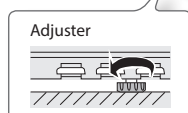

### Sostenuto pedal

This pedal sustains only the notes of the keys that were already pressed when you pressed the pedal.

### Soft pedal

This pedal is used to make the sound softer. Playing with the soft pedal depressed produces a sound that is not as strong as when otherwise played with the equivalent strength. This is the same function as the left pedal of an acoustic piano. The softness of the tone can be varied subtly by the depth to which you press the pedal.

Turn the adjuster to lower it until the adjuster is in firm contact with the floor. In particular, when you've placed the piano on carpet, you must turn the adjuster until it is pressing firmly against the floor.



### Adjusting a Value (-) [+] Buttons

Use the [-] [+] buttons to adjust a value.

|                               |  |
|-------------------------------|--|
| Changing a value continuously | Hold down the [+] button or [-] button.  |
| Changing a value rapidly      | While holding down the [+] button, press the [-] button to rapidly increase the value.<br>While holding down the [-] button, press the [+] button to rapidly decrease the value. |
| Restoring the default value   | Press the [+] button and [-] button simultaneously.  |

### Disabling the Buttons (Panel Lock)

When you activate Panel Lock, all buttons other than [Volume] are disabled. This prevents the tones or settings from being changed if you inadvertently press a button.

Press the [Other] button for a longer than usual amount of time.

#### Cancelling Panel Lock

Once again, press the [Other] button for a longer than usual amount of time.

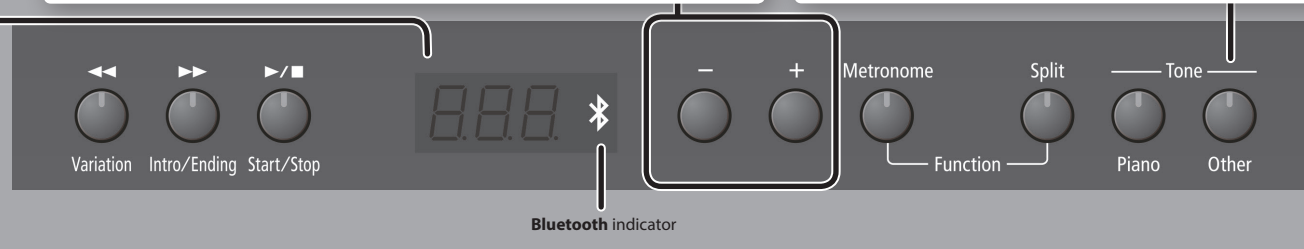

## Rear Panel Connections

### Output Jack

If you connect this jack to amplified speakers, the sound of this unit will be heard through them.



### Input Jack

If you use a cord with a stereo mini-plug to connect an audio player or similar device, the sound of the connected device will be heard through this unit. Use the controls of the connected device (audio player) to adjust the volume.



### USB Computer Port

By using a commercially available USB cable to connect the USB Computer port of this digital piano to a USB port on your computer, you can produce and edit music using MIDI-compatible software on your computer.



### DC In Jack

Place the AC adaptor so the side with the indicator (see illustration) faces upwards and the side with textual information faces downwards. The indicator will light when you plug the AC adaptor into an AC outlet.

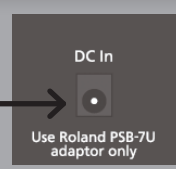
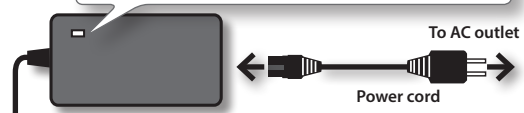

### Pedal Connector

Connect the pedal cord of the dedicated stand here.

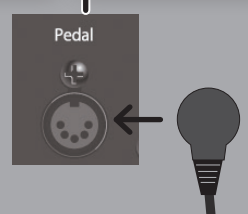

\* To prevent malfunction and equipment failure, always turn down the volume, and turn off all the units before making any connections.

## Bottom Panel (Connecting Headphones or Memory)

### PHONES Jacks

Since this unit has two headphone jacks, two people can also use headphones simultaneously.

A Headphones 3D Ambience effect will be applied, producing the sensation that the sound is emanating from the piano itself even when using headphones (p. 11).



### USB MEMORY Port

You can connect a USB flash drive here (p. 7).

Use a commercially available USB flash drive or a USB flash drive sold by Roland. However, we cannot guarantee that all commercially available USB flash drives will work with this unit.



# Before You Play

## Opening/Closing the Lid

You must use both hands to open or close the lid.

### Opening the Lid

1. Use both hands to lift the edge of the lid, and push it away from yourself.

#### NOTE

If you have any objects (papers, metal objects, etc.) placed on top of the keyboard cover, do not open the cover. Otherwise, such objects may slip inside the instrument, and then become irrecoverable.

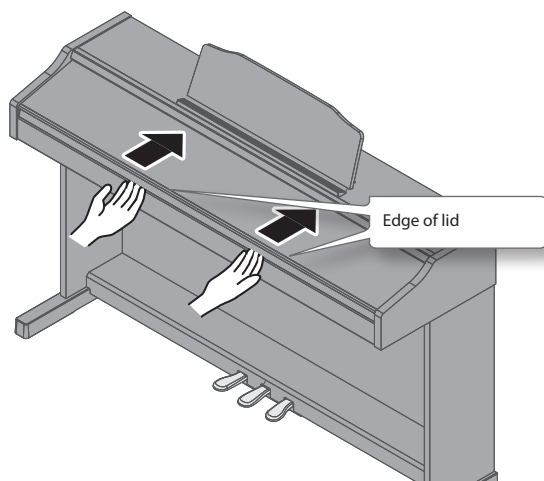

### Closing the Lid

1. Grasp and gently lower the edge of the lid with both hands.

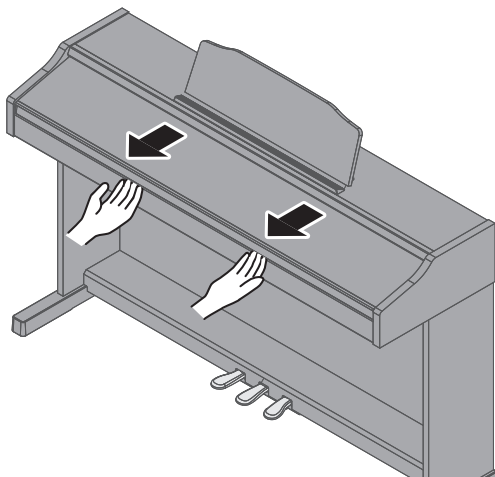

#### NOTE

- When opening or closing the lid, please be careful not to get your fingers pinched between the movable part and the panel. In places where small children are present, make sure that an adult provides supervision and guidance.
- If you need to move the piano, make sure the lid is closed first to prevent accidents.
- Do not apply undue force to the music stand while it is in use.
- Do not open the lid while objects (papers or metal items) are resting on the lid. The objects could fall into the piano and become irretrievable.

## Turning the Power On/Off

### Turning the Power On

1. Turn the [⏻] switch ON.

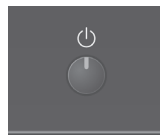

After a brief interval, you'll be able to produce sounds by playing the keyboard.

2. Use the Volume buttons to adjust the volume.

The volume increases when you press the Volume [+] button, and decreases when you press the Volume [-] button.

This will adjust the volume of the speakers if you're using the speakers of the unit, or the volume of the headphones if headphones are connected. Each volume setting (for speaker or headphone) is saved automatically.

#### MEMO

The unit is designed so that nuances in the dynamics of your playing will be clearly heard even at low volume, and that the sound will remain clear even at high volume.

### Turning the Power Off

1. Turn the [⏻] switch OFF.

## Setting the Reference Pitch

When playing ensemble with other instruments and in other such instances, you can match the standard pitch to another instrument (Master Tuning).



1. In "Various Settings (Function Mode)" (p. 11), choose "F07" and then press the [▶/■] button.
2. Use the [-] [+] buttons to set the reference pitch.

Examples:

| Reference pitch    | Display |
|--------------------|---------|
| 440.0 Hz (default) | 40.0    |
| 442.0 Hz           | 42.0    |

Press the [▶/■] button to return to the previous screen.

3. If you want to save the setting, carry out the Memory Backup procedure (p. 11).
4. Hold down the [Metronome] button and press the [Split] button to exit Function mode.

# Various Settings (Function Mode)

## Basic Operation in Function Mode

1. Hold down the [Metronome] button and press the [Split] button.  
Function mode is selected.
2. Use the [-] [+] buttons to select the function that you want to set, and press the [▶/■] button to display the setting screen.
3. Use the [-] [+] buttons to adjust the setting.  
Press the [▶/■] button to return to the previous screen.
4. Hold down the [Metronome] button and press the [Split] button to exit Function mode.

### Memory backup

The settings of this digital piano will return to their default state when you turn off the power. However, you can save the settings so they will remain unchanged even after the power has been turned off, then on again. The settings of items marked with the "M" symbol in this operating manual can be saved by using the Memory Backup function.

1. In Function mode, choose "F 19" (Memory Backup) and press the [▶/■] button.

## Function settings

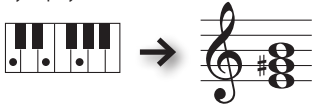
| Display | Value  | Explanation   |
|---------|--|---|
| F01     | F (Fixed),<br>L 2 (Super Light),<br>L 1 (Light),<br>M (Medium),<br>H 1 (Heavy),<br>H 2 (Super Heavy) | <h3>Adjusting the Keyboard Sensitivity (Key Touch) <span style="float: right;">M</span></h3> <p>Here's how to change the way in which the sound responds to your keyboard dynamics. You can adjust the response as appropriate for your playing strength.</p>   |
| F02     | 1 (Pair),<br>2 (Separate)  | <h3>Changing the Way in Which the Sound Is Heard (Twin Piano Mode) <span style="float: right;">M</span></h3> <p>This setting specifies how the sound will be heard when Twin Piano is on. <span style="float: right;">page 3</span></p>   |
| F03     | OFF, ON  | <h3>Dividing the Keyboard for Two-Person Performance (Twin Piano)</h3> <p>This setting turns Twin Piano on/off. <span style="float: right;">page 3</span></p>   |
| F04     | 1 (Keyboard & Song),<br>2 (Keyboard),<br>3 (Song)  | <h3>Specifying What the Transpose Will Affect (Transpose Mode) <span style="float: right;">M</span></h3> <p>This setting specifies what the transpose will affect. You can use the transpose to change the pitch of both the song and the keyboard, only the pitch of the song, or only the pitch of the keyboard.</p>  |
| F05     | -6-0-5<br>[semitone]   | <h3>Transposing the Keyboard or Song (Transpose)</h3> <p>Here you can specify the transposition value.<br/>For example, if the song is written in E major but you want to play it using the fingering of the key of C major, you would set Transpose to "4."</p> <p>If you play <b>C E G</b> → It will sound <b>E G<sup>#</sup> B</b></p>  <p>* If this is set to "0," the Transpose function will be off.</p> |
| F06     | OFF, ON  | <h3>Applying a Headphones 3D Ambience Effect to the Piano Sound (Headphones 3D Ambience) <span style="float: right;">M</span></h3> <p>You can apply a Headphones 3D Ambience effect which produces the sensation that the sound is emanating from the piano itself even when using headphones.<br/>* The Headphones 3D Ambience effect applies only to piano tones; it does not apply to other tones.<br/>On → Headphones 3D Ambience is on.<br/>Off → Headphones 3D Ambience is off.</p>         |
| F07     | 15.3 (415.3)-<br>40.0 (440.0)-<br>66.2 (466.2) [Hz]  | <h3>Matching the Pitch with Other Instruments (Master Tuning) <span style="float: right;">M</span></h3> <p>This setting specifies the reference pitch for this piano (the pitch of middle A). <span style="float: right;">page 10</span></p>  |

## Various Settings (Function Mode)

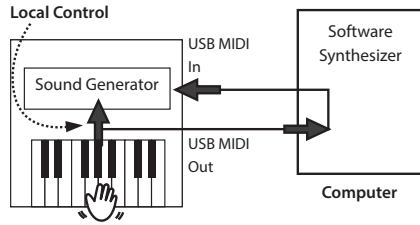
| Display                    | Value  | Explanation  |
|----------------------------|--|--|
| <b>F 08</b>                | 1, 2   | <h3>Changing the Tuning Method (Stretch Tuning) <span style="float: right;">(M)</span></h3> <p>This setting changes the type of stretch tuning, a tuning method that is used specifically for pianos, in which the high notes are tuned slightly sharper and the low notes are tuned slightly flatter.<br/>Normally, you should use the "1" setting (standard tuning curve).</p>   |
| <b>F 09</b><br><b>F 10</b> | 1 (Sostenuto, Soft),<br>2 (Start/Stop),<br>3 (Intro/Ending),<br>4 (Variation),<br>5 (Fill-in),<br>6 (Leading Bass) | <h3>Changing How the Pedals Work</h3> <p>Here you can assign the functions of the center pedal (F 09) and left pedal (F 10).</p> <p>1 → Sostenuto pedal (F 09), soft pedal (F 10)<br/>2 → Same function as the [▶/■] (Start/Stop) button<br/>3 → Intro/Ending function on/off (same function as the [▶▶] (Intro/Ending)) button<br/>4 → Variation on/off (same function as the [◀◀] (Variation)) button<br/>5 → Fill-in<br/>6 → Leading Bass function on/off</p>   |
| <b>F 11</b>                | OFF, ON  | <h3>Specifying How the Bass Part Behaves (Leading Bass) <span style="float: right;">(M)</span></h3> <p>The function that sounds the lowest note of a fingered chord as the bass tone is called "Leading Bass."</p> <p>Off → The bass part of the rhythm plays the root of the chord. For example, if you play the chord E-G-C (C major), the note C is sounded as the bass.<br/>On → The bass part plays the lowest note of the chord you play. If you play the chord E-G-C (C major), the note E is sounded as the bass.</p> <p>The Leading Bass feature is always on while Split is off.</p>   |
| <b>F 12</b>                | 1 (Intelligent),<br>2 (Standard)   | <h3>Chord Recognition When Split Is On <span style="float: right;">(M)</span></h3> <p>Sets how the unit recognizes rhythm chords while Split function (p. 2) is on.</p> <p>Intelligent → Plays chords even when basic chord tones are missing, allowing you to generate chords with very simple keyboard playing. For details on how to play chords, refer to "Chord Fingering List" at the end of this manual.<br/>Standard → Normal chord recognition.</p>   |
| <b>F 13</b>                | OFF, ON  | <h3>Preventing Doubled Notes When Connected to a Sequencer (Local Control)</h3> <p>If a software synthesizer is connected to USB MIDI, turn this item "OFF." Since most software synthesizer have their Thru function turned on, notes you play on the keyboard may be sounded in duplicate, or get dropped. To prevent this, you can enable the "Local Off" setting so that the keyboard and internal sound generator will be disconnected. If you choose "OFF," the keyboard is disconnected from the internal sound generator, and playing the keyboard will not produce sound.</p>  |
| <b>F 14</b>                | 00 1-0, 10<br>(USER 01-10)<br>00 1-0, 99<br>(USB 01-99)  | <h3>Copying a Song (Copy Song)</h3> <p>A song that you recorded on this unit can be copied to a USB flash drive.</p> <p>The copy-source song number is displayed; use the [-] [+] buttons to select the desired number, and press the [▶/■] button to confirm it.<br/>The copy-destination song number is displayed; use the [-] [+] buttons to select the desired number, and press the [▶/■] button to confirm it.</p>   |
| <b>B</b><br><b>F 15</b>    | OFF, ON  | <h3>Bluetooth Function <span style="float: right;">(M)</span></h3> <p>Turns the <b>Bluetooth</b> function on/off.</p> <p style="text-align: right;">page 14</p>  |
| <b>B</b><br><b>F 16</b>    | -P-, -P-, P-P  | <h3>Bluetooth Page-Turning/MIDI Switching <span style="float: right;">(M)</span></h3> <p>Specifies whether the <b>Bluetooth</b> function is used to turn pages or to transmit/receive MIDI messages.</p> <p>-P- → Operates (turns pages in) a music score display app on your mobile device<br/>-P- → Transmits/receives MIDI messages<br/>P-P → Operates page-turning and transmits/receives MIDI messages</p> <p style="text-align: right;">page 14</p>  |
| <b>B</b><br><b>F 17</b>    | 1, 2, 3  | <h3>Bluetooth Page-Turning Pedal Assignment <span style="float: right;">(M)</span></h3> <p>Assigns the pedals of this unit to act as key operations for the music score display app that you're using.</p> <p>1 → Cursor Up/Down<br/>2 → Page Up/Page Down<br/>3 → Cursor Left/Right</p> <p style="text-align: right;">page 15</p>   |

**B**: Only on Bluetooth-equipped models

| Display     | Value                   | Explanation  |
|-------------|-------------------------|--|
| <b>F 18</b> | OFF, 10, 30, 240 [min.] | <h2>Making the Power Automatically Turn Off After a Time (Auto Off)</h2> <p>This specifies the auto-off setting.<br/>The remaining time blinks before the power turns off. When there is less than one minute remaining, the countdown will be in seconds.<br/>* <b>This setting is saved automatically when you change it.</b></p>  |
| <b>F 19</b> | None                    | <h2>Saving the Settings (Memory Backup)</h2> <p>The settings of this digital piano will return to their default state when you turn off the power. However, you can save the settings so they will remain unchanged even after the power has been turned off, then on again.<br/>The display indicates "Sur"; press the [▶▶] (cancel) button or the [▶/■] (execute) button to cancel or execute.</p> |

page 11

## Restoring the Factory Settings (Factory Reset)

The settings you've changed in Function mode can be restored to their factory-set condition. This operation is called "Factory Reset."

### NOTE

The "Factory Reset" operation will erase all settings stored by the Memory Backup function, as well as all songs you've recorded in internal memory.

- 1. While holding down the [Metronome] button and the [Split] button, turn on the power.**  
 Keep holding down the buttons until it indicates as "Sur" on the display.  
 To cancel, press the [▶▶] button.
- 2. To execute the Factory Reset, press the [▶/■] button.**  
 When the Factory Reset has been completed, the display will indicate "End."  
 \* Never turn off the power before the display indicates "End."
- 3. Press the [⏻] switch to turn the power off, then on again.**

## Specifying the Maximum Volume (Volume Limit)

You can specify the maximum Volume setting. This will prevent undesirably high volumes even if the volume buttons are operated unintentionally.



- 1. Hold down the Volume [-] button and the Volume [+] button, and press the [-] [+] buttons to adjust the value.**

|       |                     |
|-------|---------------------|
| Value | 20, 40, 60, 80, 100 |
|-------|---------------------|

### MEMO

This setting is saved automatically when you change it.

## Provision of **Bluetooth** functionality

Please be aware that depending on the country in which you purchased the unit, **Bluetooth** functionality might not be included.

If **Bluetooth** functionality is included



## Here's What You Can Do

**Bluetooth** functionality creates a wireless connection between a mobile device such as a smartphone or tablet (subsequently referred to as the "mobile device") and this unit, allowing you to do the following.

### Page-turning

A music score display app on the mobile device can be controlled from this unit.

### MIDI data transmission and reception

MIDI data can be exchanged between this unit and the mobile device.

## Using the Pedal to Turn Pages on a Music Score App

Here's how to use this unit's pedal to operate (turn pages on) a music score app on your mobile device.

You can use the sostenuto pedal to turn to the next page, or the soft pedal to turn to the previous page.

## Note when using an already-paired iOS device

iOS

The following operation is required after each time that you switch the **Bluetooth** page-turning/MIDI function or execute a factory reset.

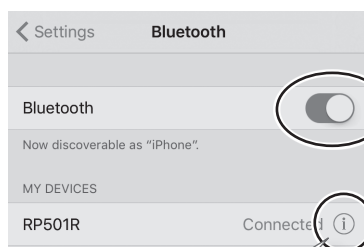

**1** Disconnect "RP501R:"

Bluetooth RP501R

Forget This Device

**2** Turn off.

For details, refer to the owner's manual of your iOS device.

**1.** Place the mobile device that you want to connect nearby this unit.

#### MEMO

If you have more than one unit of this model, power-on only the unit that you want to pair (power-off the other units).

**2.** In Function mode ([Metronome]+[Split] buttons), select "F 15" and press the [▶/■] button (p. 12).

**3.** Use the [-] [+] buttons to select "01," and then press the [▶/■] button.

**4.** Select "F 16" and press the [▶/■] button.

**5.** Use the [-] [+] buttons to select "- P -," and then press the [▶/■] button.

#### MEMO

By selecting "P - 1" here, you can use the page-turning function and the MIDI transmit/receive function simultaneously.

For example, this lets you use the pedal to operate the page-turning function while receiving MIDI to play from this instrument.

**6.** Turn on the **Bluetooth** function of the mobile device.

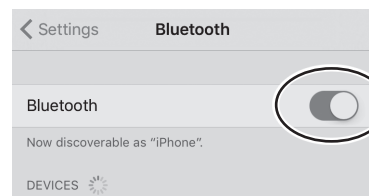

#### MEMO

The example shown here uses the iPhone. For details, refer to the owner's manual of your mobile device.

**7.** On your mobile device, tap "RP501R."

This unit will be paired with the mobile device. When pairing succeeds, the model name of this unit ("RP501R") is added to the "Paired Devices" list of the mobile device.

#### MEMO

- If you're using an iOS device (iPhone or iPad), the screen of the iOS device indicates "Bluetooth Pairing Request." Tap the [Pair] button.
- If the screen of the mobile device requests you to enter a "Pass Key," enter "0000" (four zeros).

**8.** Hold down the [Metronome] button and press the [Split] button to exit Function mode.

## If the keyboard is no longer shown on the mobile device

In some cases, depending on the mobile device app that you're using, the keyboard might stop being displayed (i.e., the keyboard might become unavailable).

If you want the mobile device's keyboard to be shown while you're using the page turning function, hold down this unit's [Metronome] button and press the [Piano] button.

To hide the mobile device's keyboard, once again hold down the [Metronome] button and press the [Piano] button.

## Connecting an Already-Paired Mobile Device

**1.** Proceed with steps 1–3 and 6 of "Using the Pedal to Turn Pages on a Music Score App" (p. 14).

This unit will be wirelessly connected to the mobile device.

**MEMO**

- If the above steps do not succeed in establishing a connection, tap the model name ("RP501R") that is shown in the **Bluetooth** device screen of the mobile device.
- To end the connection, either turn this unit's **Bluetooth** "F 15" setting "OFF" or turn your mobile device's **Bluetooth** function "off."

2. Hold down the [Metronome] button and press the [Split] button to exit Function mode.

## Changing the Operating Keys of the Page Turning Function

The key operations for turning pages will differ depending on the music score display app that you're using. You can choose which keys of this unit will operate the page turning function.

1. In Function mode ([Metronome]+[Split] buttons), select "F 17" and press the [▶/■] button (p. 12).
2. Use the [-] [+] buttons to select setting, and then press the [▶/■] button.

| Indication | Setting           | Explanation  |
|------------|-------------------|--|
| 1          | Cursor Up/Down    | The [▲] [▼] keys of the keyboard are used by the page turning app.               |
| 2          | Page Up/Page Down | The [Page Up] [Page Down] keys of the keyboard are used by the page turning app. |
| 3          | Cursor Left/Right | The [◀] [▶] keys of the keyboard are used by the page turning app.               |

3. Hold down the [Metronome] button and press the [Split] button to exit Function mode.

## Transferring MIDI Data

Here's how to make settings for transmitting and receiving MIDI data between this unit and the mobile device.

### Note when using an already-paired iOS device

iOS

The following operation is required after each time that you switch the **Bluetooth** page-turning/MIDI function or execute a factory reset.

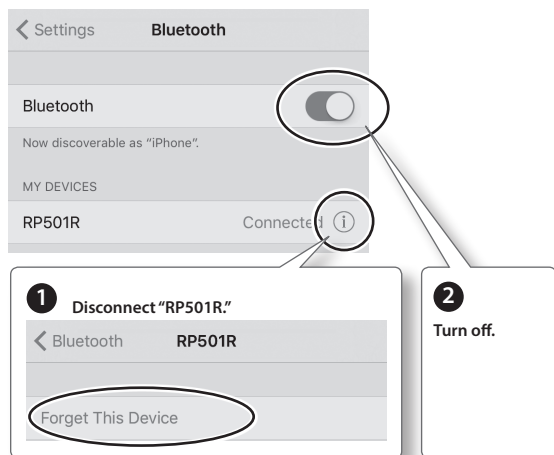

For details, refer to the owner's manual of your iOS device.

1. Place the mobile device that you want to connect nearby this unit.

**MEMO**

If you have more than one unit of this model, power-on only the unit that you want to pair (power-off the other units).

2. In Function mode ([Metronome]+[Split] buttons), select "F 15" and press the [▶/■] button (p. 12).
3. Use the [-] [+] buttons to select "ON," and then press the [▶/■] button.
4. Select "F 16" and press the [▶/■] button.
5. Use the [-] [+] buttons to select "- P -," and then press the [▶/■] button.
6. Turn on the **Bluetooth** function of the mobile device.



**MEMO**

The example shown here uses the iPhone. For details, refer to the owner's manual of your mobile device.

7. In the mobile device's app (e.g., GarageBand), establish a connection with this unit.

**NOTE**

Do not tap the "RP501R" that is shown in the **Bluetooth** settings of the mobile device.

## Problems with Bluetooth Functionality

| Problem  | Items to check/Action   |
|--|---|
| This unit does not appear in the Bluetooth device list of your mobile device | Could the <b>Bluetooth</b> function be turned "OFF"?  |
|  | If the <b>Bluetooth</b> function (F 15) is "ON" and the <b>Bluetooth</b> Turn/MIDI function (F 16) is set to "- P -" A device named "RP501R" appears.   |
|  | If the <b>Bluetooth</b> function (F 15) is "ON" and the <b>Bluetooth</b> Turn/MIDI function (F 16) is set to "- P -" You can check this from a setting inside your app such as GarageBand.  |
|  | If the <b>Bluetooth</b> function (F 15) is "ON" and the <b>Bluetooth</b> Turn/MIDI function (F 16) is set to "P - P" A device named "RP501R" appears. And you can check this from a setting inside your app such as GarageBand.   |
| Can't connect to Bluetooth page turning                                      | In some cases, the connection with the mobile device might become unavailable when you switch the <b>Bluetooth</b> Turn/MIDI function (F 16). After unpairing the "RP501R" that is registered on the mobile device, turn the mobile device's <b>Bluetooth</b> function off and then on again, and reconnect it. |
| Can't connect to Bluetooth MIDI  | In some cases, the connection with the mobile device might become unavailable when you switch the <b>Bluetooth</b> Turn/MIDI function (F 16). After unpairing the "RP501R" that is registered on the mobile device, turn the mobile device's <b>Bluetooth</b> function off and then on again, and reconnect it. |
| Can't connect via MIDI   | <b>Bluetooth</b> MIDI is only compatible with iOS. Also, you must make the connection not from the mobile device's <b>Bluetooth</b> setting but from the setting within GarageBand or other app that you're using.  |
| Can't pair   | This unit's <b>Bluetooth</b> function establishes pairing the first time you select and pair it from your mobile device. You don't need to initiate pairing from this unit.   |

English

Deutsch

Français

Italiano

Español

Português

Nederlands

## Using the Bluetooth® Functionality

| Problem   | Items to check/Action   |
|---|---|
| Can't use the page turning function and MIDI function simultaneously  | Set the <b>Bluetooth</b> Turn/MIDI function (F 15) to "P - N."  |
| Can't connect a paired mobile device                                  | If the connection breaks immediately after it is established, or when you switch the page turning function and MIDI data transmit/receive function, turning the <b>Bluetooth</b> device's <b>Bluetooth</b> switch off and then on again may allow connection to occur.  |
| Keyboard no longer appears (becomes unavailable) on the mobile device | When using the page turning function, the keyboard might not be shown (might be unavailable) depending on the mobile device that you're using.<br>If you want the mobile device's keyboard to be shown while you're using the page turning function, hold down this unit's [Metronome] button and press the [Piano] button.<br>To hide the mobile device's keyboard, hold down the [Metronome] button and press the [Piano] button. |

## Troubleshooting

| Problem  | Cause/Action   |
|--|--|
| Even though you're using headphones and the sound is muted, a thumping sound is heard when you play the keyboard | This unit uses a hammer action keyboard in order to simulate an acoustic piano's playing touch as realistically as possible. For this reason, you'll hear the hammers thump when you play the keyboard, just as you would when playing an acoustic piano. Since this unit allows you to adjust its volume, you might notice the sound of the hammers in certain situations, but this does not indicate a malfunction. If vibration transmitted to the floor or walls is a concern, you may be able to minimize the vibration by moving the piano away from the wall, or by laying down a commercially available anti-vibration mat designed for use with pianos. |
| Power turns off on its own   | When 30 minutes have elapsed since you last played or operated this unit, the power will turn off automatically. (This is the factory setting.) If you don't need the power to turn off automatically, turn the "Auto Off" setting off (p. 13).  |
| Power does not turn on   | Is the AC adaptor connected correctly? (p. 9)  |
| Pedal does not work, or is "stuck"   | Is the pedal connected correctly?<br>Plug the cord firmly into the pedal connector (p. 9).   |
|  | If you disconnect the pedal cord from the unit while the power is on, the pedal effect may remain "stuck" in the On condition.<br>You must power-off the unit before connecting or disconnecting the pedal cord.   |
|  | Could Twin Piano be turned on?<br>If Twin Piano is on, the right pedal will affect only the right-hand keyboard zone and the left pedal will affect only the left-hand keyboard zone (p. 3).   |
|  | Could you have changed the function of the pedal (F 9, F 10)? (p. 12)<br>Could you be using the page-turning function? (p. 14)   |
| Insufficient volume  | Could the volume limit setting have lowered the maximum volume?<br>The volume can't be louder than the specified volume limit. Change the volume limit setting (p. 13).  |
| The volume level of the instrument connected to Input jack is too low  | Could you be using a connection cable that contains a resistor?<br>Use a connection cable that does not contain a resistor.  |
| No sound/No sound when you play back a song  | Could the unit's volume or the volume of the connected equipment be turned down?   |
|  | Could headphones be connected?<br>Could there be a plug inserted in a headphone jack?<br>The speakers will not produce sound if headphones or plug are connected to the headphone jacks (p. 9).  |
|  | Has Local Control been set to "Off"?<br>When Local Control is set to Off, no sound is produced on the keyboard. Set Local Control to On (p. 12).   |
| Not all the notes you play are sounded   | The maximum simultaneous polyphony is 128 voices. If you're using the Dual tone (p. 2), if you're playing along with a song, or if you're making extensive use of the damper pedal, the performance data may exceed the available polyphony, possibly causing some of the notes you play to drop out.  |

| Problem   | Cause/Action  |
|---|---|
| Pitch of the keyboard or song is incorrect                              | Could you have made Transpose settings? (p. 11)   |
|   | Is the Master Tune setting appropriate? (p. 10)<br>The notes of a piano are tuned using a unique method (stretched tuning), which makes upper-range notes slightly higher in pitch, and lower-range notes slightly lower in pitch. For this reason, you might perceive the pitch as being incorrect, but this is the way an acoustic piano should sound.  |
| Sounds are heard twice (doubled) when the keyboard is played            | Could you have selected a dual tone? (p. 2)<br>When this unit is connected to an external sequencer, set the Local Control to off. Alternatively, the sequencer could be set so its Soft Thru feature is Off (p. 12).   |
| Reverberation remains even though you've turned off the Ambience effect | The piano sounds of this digital piano faithfully simulate the sense of depth and resonance of an acoustic piano. For this reason, it may seem as though there is some reverberation even when the Ambience effect is turned off.   |
| The sound of the higher notes suddenly changes from a certain key       | On an acoustic piano, the approximately one and a half octaves of notes at the upper end of the keyboard will continue sounding regardless of the damper pedal. These notes also have a somewhat different tonal character.<br>This unit faithfully simulate this characteristic of acoustic pianos. On this unit, the range that is unaffected by the damper pedal will change according to the transpose setting.   |
| High-pitched ringing is heard   | <b>If you hear this in headphones:</b><br>Piano sounds that have a brilliant and crisp character contain substantial high-frequency components that may sound as though a metallic ringing has been added. This is because the characteristics of an actual piano are being faithfully reproduced, and is not a malfunction. This ringing is more obtrusive if the ambience effect is applied heavily, so you may be able to minimize it by decreasing the ambience.  |
|   | <b>If you don't hear this in headphones:</b><br>It is likely that there is some other reason (such as resonances within the unit). Please contact your dealer, the nearest Roland Service Center, or an authorized Roland distributor, as listed on the "Information."  |
| Sound wrong, or are buzzy   | If you set the volume to the maximum setting, the sound may be distorted depending on how you perform. If this occurs, turn down the volume.  |
|   | <b>If you don't hear this in headphones:</b><br>Performing at high volumes may cause the speakers or objects near the unit to resonate. Fluorescent lights or glass doors may also resonate sympathetically. In particular, this is more likely to occur for lower notes and higher volumes. You can take the following measures to minimize resonances.<br>• Locate this unit 10–15 cm (4–6 inch) away from walls or other surfaces.<br>• Keep the volume down.<br>• Move away from the objects that are resonating. |
|   | <b>If you hear this in headphones:</b><br>It is likely that there is some other reason. Please contact your dealer, the nearest Roland Service Center, or an authorized Roland distributor, as listed on the "Information."   |



# Message List

| Indication             | Meaning   |
|------------------------|---|
| <b>E.01</b>            | The music file you attempted to save is read-only. It cannot be saved.  |
| <b>E.02</b>            | An error occurred while writing. It may be that the protect tab of the external media is in the "Protect (write prohibit)" position, or that the external media has not been formatted. |
| <b>E.10</b>            | No USB flash drive connected. Connect a USB flash drive and try the operation again.  |
| <b>E.11</b>            | There is insufficient free space at the save destination. Either connect a different USB flash drive, or delete unwanted data (song data) and try the operation again.                  |
| <b>E.14</b>            | An error occurred while reading. The USB flash drive may be damaged. Connect a different USB flash drive and try the operation again. You may also format the USB flash drive (p. 7).   |
| <b>E.15</b>            | The file could not be read. The data format is not compatible with the unit.  |
| <b>E.16</b>            | The data could not be read fast enough during song playback. After waiting several seconds, you may be able to play back the song by pressing the [▶/■] button once again.              |
| <b>E.18</b>            | This audio format is not supported. Please use WAV format, 44.1 kHz, 16-bit linear audio files.   |
| <b>E.30</b>            | The unit's internal memory is full.   |
| <b>E.40</b>            | The unit cannot deal with the excessive MIDI data sent from the external USB MIDI.<br>Reduce the amount of MIDI data sent to the unit.  |
| <b>E.51</b>            | There may be a problem with the system.<br>Repeat the procedure from the beginning. If it is not solved after you have tried a number of times, contact the Roland service center.      |
| <b>E.65</b>            | The USB flash drive connector was subjected to excessive current.<br>Make sure that there is no problem with the external media, then turn the power off, then on again.                |
| <b>- - -</b>           | The Panel Lock function is on (p. 9).   |
| <b>PU</b>              | When playing back a song, this is shown if the song starts on an upbeat.  |
| <b>Blinking number</b> | When the Auto Off function is activated, the remaining time blinks before the power turns off.  |

English

Deutsch

Français

Italiano

Español

Português

Nederlands

# USING THE UNIT SAFELY

## ⚠ WARNING

### Concerning the Auto Off function

The power to this unit will be turned off automatically after a predetermined amount of time has passed since it was last used for playing music, or its buttons or controls were operated (Auto Off function). If you do not want the power to be turned off automatically, disengage the Auto Off function (p. 13).



### Use only the supplied AC adaptor and the correct voltage

Be sure to use only the AC adaptor supplied with the unit. Also, make sure the line voltage at the installation matches the input voltage specified on the AC adaptor's body. Other AC adaptors may use a different polarity, or be designed for a different voltage, so their use could result in damage, malfunction, or electric shock.



### Use only the supplied power cord

Use only the attached power cord. Also, the supplied power cord must not be used with any other device.



## ⚠ CAUTION

### Cautions when moving this unit

If you need to move the instrument, take note of the precautions listed below. At least two persons are required to safely lift and move the unit. It should be handled carefully, all the while keeping it level. Make sure to have a firm grip, to protect yourself from injury and the instrument from damage.



- Check to make sure the screws securing the unit to the side boards have not become loose. Fasten them again securely whenever you notice any loosening.
- Disconnect the power cord.
- Disconnect all cords coming from external devices.
- Raise the adjusters on the stand (p. 8).
- Close the lid.
- Remove the music stand.

## ⚠ CAUTION

### Take care so as not to get fingers pinched

When handling the following moving parts, take care so as not to get fingers, toes, etc., pinched. Whenever a child uses the unit, an adult should be on hand to provide supervision and guidance.



- Lid cover (p. 10)
- Pedals (p. 8)

## ⚠ CAUTION

### Keep small items out of the reach of children

To prevent accidental ingestion of the parts listed below, always keep them out of the reach of small children.



- Included Parts/Removable Parts  
Screws

### Precautions concerning use of bench

When using the bench, please observe the following points:



- Do not use the bench as a toy, or as a stepping stool.
- Do not allow two or more persons to sit on the bench.
- Do not adjust the height while sitting on the bench.
- Do not sit on the bench if the bolts holding the bench legs are loose. (If the bolts are loose, immediately re-tighten them using the supplied tool.)
- Never insert your hand into the gap (the metal height adjustment mechanism) under the seat lid. Doing so may cause your hand to be pinched or injured.



# IMPORTANT NOTES

## Placement

- Do not allow lighting devices that normally are used while their light source is very close to the unit (such as a piano light), or powerful spotlights to shine upon the same area of the unit for extended periods of time. Excessive heat can deform or discolor the unit.
- Do not allow objects to remain on top of the keyboard. This can be the cause of malfunction, such as keys ceasing to produce sound.

## Maintenance

- To clean the unit, use a dry, soft cloth; or one that is slightly dampened. Try to wipe the entire surface using an equal amount of strength, moving the cloth along with the grain of the wood. Rubbing too hard in the same area can damage the finish.

## Care of the Keyboard

- Do not write on the keyboard with any pen or other implement, and do not stamp or place any marking on the instrument. Ink will seep into the surface lines and become unremovable.
- Do not affix stickers on the keyboard. You may be unable to remove stickers that use strong adhesives, and the adhesive may cause discoloration.
- To remove stubborn dirt, use a commercially available keyboard cleaner that does not contain abrasives. Start by wiping lightly. If the dirt does not come off, wipe using gradually increasing amounts of pressure while taking care not to scratch the keys.

## Repairs and Data

- Before sending the unit away for repairs, be sure to make a backup of the data stored within it; or you may prefer to write down the needed information. Although we will do our utmost to preserve the data stored in your unit when we carry out repairs, in some cases, such as when the memory section is physically damaged, restoration of the stored content may be impossible. Roland assumes no liability concerning the restoration of any stored content that has been lost.

## Additional Precautions

- Any data stored within the unit can be lost as the result of equipment failure, incorrect operation, etc. To protect yourself against the irretrievable loss of data, try to make a habit of creating regular backups of the data you've stored in the unit.
- Roland assumes no liability concerning the restoration of any stored content that has been lost.
- Never strike or apply strong pressure to the display.
- The sound of keys being struck and vibrations produced by playing an instrument can be transmitted through a floor or wall to an unexpected extent. Please take care not to cause annoyance to others nearby.
- Do not apply undue force to the music stand while it is in use.
- Do not use connection cables that contain a built-in resistor.
- Do not hang anything other than headphones on the headphone hook. Do not apply undue force to the hook. Otherwise, you risk damaging the hook.

## Using External Memories

- Please observe the following precautions when handling external memory devices. Also, make sure to carefully observe all the precautions that were supplied with the external memory device.
  - Do not remove the device while reading/writing is in progress.
  - To prevent damage from static electricity, discharge all static electricity from your person before handling the device.

## Caution Regarding Radio Frequency Emissions

- The following actions may subject you to penalty of law.
  - Disassembling or modifying this device.
  - Removing the certification label affixed to the back of this device.

## Intellectual Property Right

- It is forbidden by law to make an audio recording, video recording, copy or revision of a third party's copyrighted work (musical work, video work, broadcast, live performance, or other work), whether in whole or in part, and distribute, sell, lease, perform, or broadcast it without the permission of the copyright owner.
  - Do not use this product for purposes that could infringe on a copyright held by a third party. We assume no responsibility whatsoever with regard to any infringements of third-party copyrights arising through your use of this product.
  - The copyright of content in this product (the sound waveform data, style data, accompaniment patterns, phrase data, audio loops and image data) is reserved by Roland Corporation.
- Purchasers of this product are permitted to utilize said content (except song data such as Demo Songs) for the creating, performing, recording and distributing original musical works.
  - Purchasers of this product are NOT permitted to extract said content in original or modified form, for the purpose of distributing recorded medium of said content or making them available on a computer network.
  - MMP (Moore Microprocessor Portfolio) refers to a patent portfolio concerned with microprocessor architecture, which was developed by Technology Properties Limited (TPL). Roland has licensed this technology from the TPL Group.
  - XGlite (XG) is a registered trademark or a trademark of Yamaha Corporation.
  - The **Bluetooth**® word mark and logos are registered trademarks owned by Bluetooth SIG, Inc. and any use of such marks by Roland is under license.
  - Roland, BOSS, SuperNATURAL and GS are either registered trademarks or trademarks of Roland Corporation in the United States and/or other countries.
  - Company names and product names appearing in this document are registered trademarks or trademarks of their respective owners

# Tone List

## [Piano] button

| No. | Name          |
|-----|---------------|
| 1   | Concert Piano |
| 2   | Ballade Piano |
| 3   | Bright Piano  |

| No. | Name            |
|-----|-----------------|
| 4   | Magical Piano   |
| 5   | Piano + Strings |
| 6   | Piano + Pad     |

| No. | Name          |
|-----|---------------|
| 7   | Piano + Choir |
| 8   | Rock Piano    |
| 9   | Ragtime Piano |

| No. | Name                |
|-----|---------------------|
| 10  | Harpischord         |
| 11  | Coupled Harpischord |

## [Other] button

| No. | Name         |
|-----|--------------|
| 1   | Trem. TineEP |
| 2   | Pop E.Piano  |
| 3   | Tine EP      |
| 4   | FM E.Piano   |
| 5   | Bright FM EP |
| 6   | Vib. ReedEP  |
| 7   | Clav.        |
| 8   | PhaserTineEP |
| 9   | Vibraphone   |
| 10  | Marimba      |
| 11  | Celesta      |

| No. | Name         |
|-----|--------------|
| 12  | Mallet Isle  |
| 13  | Morning Lite |
| 14  | SymphonicStr |
| 15  | Rich Strings |
| 16  | OrchestraStr |
| 17  | DecayStrings |
| 18  | Harp         |
| 19  | PizzicatoStr |
| 20  | ChurchOrgan1 |
| 21  | ChurchOrgan2 |
| 22  | Combo Jz.Org |

| No. | Name         |
|-----|--------------|
| 23  | Ballad Organ |
| 24  | Full Stops   |
| 25  | Mellow Bars  |
| 26  | Accordion    |
| 27  | Aerial Choir |
| 28  | Jazz Scat    |
| 29  | Female Aahs  |
| 30  | Male Aahs    |
| 31  | Decay Choir  |
| 32  | Thum Voice   |
| 33  | Soft Pad     |

| No. | Name         |
|-----|--------------|
| 34  | Dcy ChoirPad |
| 35  | Nylon-str.Gt |
| 36  | Steel-str.Gt |
| 37  | Jazz Guitar  |
| 38  | AcousticBass |
| 39  | A.Bass+CymbI |
| 40  | FingeredBass |
| 41  | GM2 tones    |
| 305 |              |

# Rhythm List

| Genre       | No. | Name             |
|-------------|-----|------------------|
| Pop         | 1-1 | Gold Medium Beat |
|             | 1-2 | Frank's Way      |
|             | 1-3 | Gold Slow Beat   |
|             | 1-4 | Gold Beat        |
|             | 1-5 | Jessie Beat      |
|             | 1-6 | US Shuffle       |
|             | 1-7 | Strummin' Pop    |
|             | 1-8 | Unplugged Pop    |
|             | 1-9 | Amazing Gospel   |
| Ballad Rock | 2-1 | Easy Ballad      |
|             | 2-2 | Acoustic Ballad  |
|             | 2-3 | Love Slow Rock   |
|             | 2-4 | Unplugged Ballad |
|             | 2-5 | Spring Rock      |
|             | 2-6 | Joe's Rock       |
|             | 2-7 | Breaky Rock      |
| Disco       | 3-1 | Seventies        |
|             | 3-2 | Jamiro Dance     |

| Genre     | No.        | Name            |                     |
|-----------|------------|-----------------|---------------------|
| Disco     | 3-3        | Gold Disco      |                     |
|           | 3-4        | Survive Disco   |                     |
|           | 3-5        | Hitmix          |                     |
|           | 3-6        | Club House      |                     |
|           | 3-7        | Baby Beat       |                     |
|           | 3-8        | Breath Rap      |                     |
|           | 3-9        | Now Hip Hop     |                     |
|           | Jazz Blues | 4-1             | Gold Swing          |
|           |            | 4-2             | Midnight Slow Swing |
| 4-3       |            | Big Band Medium |                     |
| 4-4       |            | Slow Jazz Waltz |                     |
| 4-5       |            | Cool Soul       |                     |
| 4-6       |            | Cool Blues      |                     |
| 4-7       |            | Go! Rock'N      |                     |
| 4-8       |            | Blue Boogie     |                     |
| 4-9       |            | Rock'N Slow     |                     |
| Ball Room | 5-1        | It Valzer       |                     |
|           | 5-2        | Gold Wien Waltz |                     |

| Genre        | No.   | Name            |             |
|--------------|-------|-----------------|-------------|
| Ball Room    | 5-3   | Gold Slow Waltz |             |
|              | 5-4   | Polka Disco     |             |
|              | 5-5   | Gold Tango      |             |
|              | 5-6   | Gold Foxtrot    |             |
|              | 5-7   | Quick Step      |             |
|              | 5-8   | Go! Twist       |             |
|              | Latin | 6-1             | Gold Rhumba |
|              |       | 6-2             | Beguine     |
| 6-3          |       | Gold Cha Cha    |             |
| 6-4          |       | That's Mambo    |             |
| 6-5          |       | Cuba Salsa      |             |
| 6-6          |       | Acoustic Samba  |             |
| 6-7          |       | Jazz Bossa      |             |
| 6-8          |       | Fast Bossa      |             |
| 6-9          |       | Samba           |             |
| Tradit World | 7-1   | Pop Reggae      |             |
|              | 7-2   | Love Reggae     |             |
|              | 7-3   | Gospel Shuffle  |             |
|              | 7-4   | Ska             |             |

| Genre        | No. | Name             |
|--------------|-----|------------------|
| Tradit World | 7-5 | German Polka     |
|              | 7-6 | German Waltz     |
|              | 7-7 | 6_8 March        |
|              | 7-8 | US March         |
|              | 7-9 | Orchestral Waltz |
| Country      | 8-1 | Country Rock     |
|              | 8-2 | Country Flyer    |
|              | 8-3 | Southern Twang   |
|              | 8-4 | Country Ballad   |
|              | 8-5 | Country Beat     |
|              | 8-6 | Country Pop      |
| Pianist      | 9-1 | P. Arpeggio      |
|              | 9-2 | P. Pop           |
|              | 9-3 | P. Classic Polka |
|              | 9-4 | P. Waltz         |
|              | 9-5 | P. Boogie        |
|              | 9-6 | P. Ragtime       |

# Chord Fingering List

|          |           |          |                   |          |          |
|----------|-----------|----------|-------------------|----------|----------|
| C        | C#        | D        | E $\flat$         | E        | F        |
| CM7      | C#M7      | DM7      | E $\flat$ M7      | EM7      | FM7      |
| C7       | C#7       | D7       | E $\flat$ 7       | E7       | F7       |
| Cm       | C#m       | Dm       | E $\flat$ m       | Em       | Fm       |
| Cm7      | C#m7      | Dm7      | E $\flat$ m7      | Em7      | Fm7      |
| CmM7     | C#mM7     | DmM7     | E $\flat$ mM7     | EmM7     | FmM7     |
| Cdim     | C#dim     | Ddim     | E $\flat$ dim     | Edim     | Fdim     |
| Cm7 (b5) | C#m7 (b5) | Dm7 (b5) | E $\flat$ m7 (b5) | Em7 (b5) | Fm7 (b5) |
| Caug     | C#aug     | Daug     | E $\flat$ aug     | Eaug     | Faug     |
| Csus4    | C#sus4    | Dsus4    | E $\flat$ sus4    | Esus4    | Fsus4    |
| C7sus4   | C#7sus4   | D7sus4   | E $\flat$ 7sus4   | E7sus4   | F7sus4   |
| C7/13    | C#7/13    | D7/13    | E $\flat$ 7/13    | E7/13    | F7/13    |

F# G Ab A Bb B

F#M7 GM7 AbM7 AM7 Bb M7 BM7

F#7 G7 Ab7 A7 Bb 7 B7

F#m Gm Abm Am Bb m Bm

F#m7 Gm7 Abm7 Am7 Bb m7 Bm7

F#mM7 GmM7 AbmM7 AmM7 Bb mM7 BmM7

F#dim Gdim Abdim Adim Bb dim Bdim

F#m7 (b5) Gm7 (b5) Abm7 (b5) Am7 (b5) Bb m7 (b5) Bm7 (b5)

F#aug Gaug Abaug Aaug Bb aug Baug

F#sus4 Gsus4 Absus4 Asus4 Bb sus4 Bsus4

F#7sus4 G7sus4 Ab7sus4 A7sus4 Bb 7sus4 B7sus4

F#7/13 G7/13 Ab7/13 A7/13 Bb 7/13 B7/13

# Internal Song List

| No.  | Song Name                    | Composer   |
|------|------------------------------|--|
| 2.01 | Valse, op.34-1               | Fryderyk Franciszek Chopin                       |
| 2.02 | Polonaise op.53              | Fryderyk Franciszek Chopin                       |
| 2.03 | Nocturne No.20               | Fryderyk Franciszek Chopin                       |
| 2.04 | Die Forelle                  | Franz Peter Schubert,<br>Arranged by Franz Liszt |
| 2.05 | Reflets dans l'Eau           | Claude Achille Debussy                           |
| 2.06 | La Fille aux Cheveux de Lin  | Claude Achille Debussy                           |
| 2.07 | La Campanella                | Franz Liszt                                      |
| 2.08 | Scherzo No.2                 | Fryderyk Franciszek Chopin                       |
| 2.09 | Étude, op.10-12              | Fryderyk Franciszek Chopin                       |
| 2.10 | Sonate Nr.16 C Dur           | Wolfgang Amadeus Mozart                          |
| 2.11 | Liebesträume Nr.3            | Franz Liszt                                      |
| 2.12 | Étude, op.10-3               | Fryderyk Franciszek Chopin                       |
| 2.13 | Je te veux                   | Erik Satie                                       |
| 2.14 | Valse, op.64-1               | Fryderyk Franciszek Chopin                       |
| 2.15 | Golliwog's Cakewalk          | Claude Achille Debussy                           |
| 2.16 | Fantaisie-Impromptu          | Fryderyk Franciszek Chopin                       |
| 2.17 | 1ère Arabesque               | Claude Achille Debussy                           |
| 2.18 | An der schönen, blauen Donau | Johann Strauss, Sohn                             |
| 2.19 | Auf Flügeln des Gesanges     | Felix Mendelssohn                                |
| 2.20 | Mazurka No.5                 | Fryderyk Franciszek Chopin                       |
| 2.21 | 1ère Gymnopédie              | Erik Satie                                       |
| 2.22 | Étude, op.25-1               | Fryderyk Franciszek Chopin                       |
| 2.23 | Clair de Lune                | Claude Achille Debussy                           |
| 2.24 | Étude, op.10-5               | Fryderyk Franciszek Chopin                       |
| 2.25 | Dr. Gradus ad Parnassum      | Claude Achille Debussy                           |
| 2.26 | Grande Valse Brillante       | Fryderyk Franciszek Chopin                       |
| 2.27 | La prière d'une Vierge       | Tekla Badarzewska                                |
| 2.28 | Course en Troïka             | Peter Ilyich Tchaikovsky                         |
| 2.29 | To The Spring                | Edvard Hagerup Grieg                             |
| 2.30 | Valse, op.64-2               | Fryderyk Franciszek Chopin                       |
| 2.31 | Radetzky Marsch              | Johann Baptist Strauss                           |
| 2.32 | Träumerei                    | Robert Alexander Schumann                        |
| 2.33 | Moments Musicaux op.94-3     | Franz Peter Schubert                             |
| 2.34 | Prélude, op.28-15            | Fryderyk Franciszek Chopin                       |
| 2.35 | The Harmonious Blacksmith    | Georg Friedrich Händel                           |
| 2.36 | Ungarische Tänze Nr.5        | Johannes Brahms                                  |
| 2.37 | Türkischer Marsch            | Ludwig van Beethoven                             |
| 2.38 | Nocturne, op.9-2             | Fryderyk Franciszek Chopin                       |
| 2.39 | Frühlingslied                | Felix Mendelssohn                                |
| 2.40 | Präludium C Dur BWV846       | Johann Sebastian Bach                            |
| 2.41 | Jägerlied                    | Felix Mendelssohn                                |
| 2.42 | Passepied                    | Claude Achille Debussy                           |
| 2.43 | Für Elise                    | Ludwig van Beethoven                             |
| 2.44 | Türkischer Marsch            | Wolfgang Amadeus Mozart                          |
| 2.45 | Ständchen                    | Franz Peter Schubert                             |
| 2.46 | Humoreske                    | Antonín Dvořák                                   |
| 2.47 | Blumenlied                   | Gustav Lange                                     |
| 2.48 | Alpenglöckchen               | Theodor Oesten                                   |
| 2.49 | Menuett G dur                | Ludwig van Beethoven                             |
| 2.50 | Venezianisches Gondellied    | Felix Mendelssohn                                |
| 2.51 | Alpenabendröte               | Theodor Oesten                                   |
| 2.52 | Farewell to the Piano        | Ludwig van Beethoven                             |
| 2.53 | Brautchor                    | Wilhelm Richard Wagner                           |
| 2.54 | Forget-Me-Not                | Heinrich Lichner                                 |
| 2.55 | Wiener Marsch                | Carl Czerny                                      |
| 2.56 | Le Coucou                    | Louis Claude Daquin                              |
| 2.57 | Menuett G Dur BWV Anh.114    | Johann Sebastian Bach                            |
| 2.58 | Spinnerlied                  | Albert Ellmenreich                               |
| 2.59 | Gavotte                      | François Joseph Gossec                           |
| 2.60 | Heidenröslein                | Gustav Lange                                     |

| No.  | Song Name   | Composer                  |
|------|---|---------------------------|
| 2.61 | Zigeuner Tanz                                     | Heinrich Lichner          |
| 2.62 | La Cinquantaine                                   | Gabriel Marie             |
| 2.63 | Csikos Post                                       | Hermann Necke             |
| 2.64 | Dolly's Dreaming Awakening                        | Theodor Oesten            |
| 2.65 | La Violette                                       | Louis Streabbog           |
| 2.66 | Fröhlicher Landmann                               | Robert Alexander Schumann |
| 2.67 | Sonatine op.36-1                                  | Muzio Clementi            |
| 2.68 | Sonatine op.20-1                                  | Friedrich Kuhlau          |
| 2.69 | Sonatine No.5                                     | Ludwig van Beethoven      |
| 2.70 | Twinkle Twinkle Little Star                       | French Folk Song          |
| 2.71 | Mary Had a Little Lamb                            | Traditional               |
| 2.72 | Bear Song   | American Folk Song        |
| 2.73 | Ich Bin Ein Musikante                             | German Folk Song          |
| 2.74 | Grand Father's Clock                              | Henry Work                |
| 2.75 | Maple Leaf Rag                                    | Scott Joplin              |
| 2.76 | Le Quattro Stagioni "La Primavera"                | Antonio Vivaldi           |
| 2.77 | Marche Militaire Nr.1                             | Franz Peter Schubert      |
| 6.01 | Czerny 100-1-99                                   | Carl Czerny               |
| 6.99 |   |                           |
| 6.00 | Czerny 100-100                                    | Carl Czerny               |
| c.01 | Hanon 1-20  | Charles Hanon             |
| c.20 |   |                           |
| d.01 | Major Scales,<br>Minor Scales (Harmonic, Melodic) | —                         |
| d.36 |   |                           |

\* All rights reserved. Unauthorized use of this material for purposes other than private, personal enjoyment is a violation of applicable laws.

\* Musical scores are not included with this unit. You can purchase musical scores from their respective publishers.



For the U.K.

**IMPORTANT:** THE WIRES IN THIS MAINS LEAD ARE COLOURED IN ACCORDANCE WITH THE FOLLOWING CODE.

BLUE: NEUTRAL  
BROWN: LIVE

As the colours of the wires in the mains lead of this apparatus may not correspond with the coloured markings identifying the terminals in your plug, proceed as follows:

The wire which is coloured BLUE must be connected to the terminal which is marked with the letter N or coloured BLACK.

The wire which is coloured BROWN must be connected to the terminal which is marked with the letter L or coloured RED.

Under no circumstances must either of the above wires be connected to the earth terminal of a three pin plug.

For the USA

## **DECLARATION OF CONFORMITY Compliance Information Statement**

Model Name : RP501R

Type of Equipment : Digital Piano

Responsible Party : Roland Corporation U.S.

Address : 5100 S. Eastern Avenue Los Angeles, CA 90040-2938

Telephone : (323) 890-3700



**For the USA**

This transmitter must not be co-located or operated in conjunction with any other antenna or transmitter.

(FCC Part15 Subpart C §15.247, 15.253, 15.255)

This equipment complies with FCC radiation exposure limits set forth for an uncontrolled environment and meets the FCC radio frequency (RF) Exposure Guidelines. This equipment has very low levels of RF energy that it deemed to comply without maximum permissive exposure evaluation (MPE).

(FCC Part15 Subpart C §15.247, 15.253, 15.255)

**For Canada**

This device complies with Industry Canada licence-exempt RSS standard(s). Operation is subject to the following two conditions: (1) this device may not cause interference, and (2) this device must accept any interference, including interference that may cause undesired operation of the device.

Le présent appareil est conforme aux CNR d'Industrie Canada applicables aux appareils radio exempts de licence. L'exploitation est autorisée aux deux conditions suivantes : (1) l'appareil ne doit pas produire de brouillage, et (2) l'utilisateur de l'appareil doit accepter tout brouillage radioélectrique subi, même si le brouillage est susceptible d'en compromettre le fonctionnement.

(RSS-Gen §7.1.3)

This equipment complies with IC radiation exposure limits set forth for an uncontrolled environment and meets RSS-102 of the IC radio frequency (RF) Exposure rules. This equipment has very low levels of RF energy that it deemed to comply without maximum permissive exposure evaluation (MPE).

Cet équipement est conforme aux limites d'exposition aux rayonnements énoncées pour un environnement non contrôlé et respecte les règles d'exposition aux fréquences radioélectriques (RF) CNR-102 de l'IC. Cet équipement émet une énergie RF très faible qui est considérée conforme sans évaluation de l'exposition maximale autorisée.

(RSS-102 §2.6)

**For EU countries****European Community Declaration of Conformity**

Hereby, Roland Corporation, declares that this RP501R is in compliance with the essential requirements and other relevant provisions of Directive 2014/53/EU.

|                   |   |
|-------------------|---|
| <b>English</b>    | Hereby, Roland Corporation, declares that this RP501R is in compliance with the essential requirements and other relevant provisions of Directive 2014/53/EU.                                       |
| <b>Bulgarian</b>  | С настоящето, Roland Corporation, декларира, че RP501R е в съответствие със съществените изисквания и другитеприложими разпоредби на Директива 2014/53/EU.  |
| <b>Czech</b>      | Roland Corporation tímto prohlašuje, že RP501R splňuje základní požadavky a všechna příslušná ustanovení Směrnice 1999/5/ES.  |
| <b>Danish</b>     | Undertegnede Roland Corporation erklærer herved, at følgende udstyr RP501R overholder de væsentlige krav og øvrige relevante krav i direktiv 1999/5/EF.   |
| <b>German</b>     | Hiermit erklärt Roland Corporation, dass sich das Gerät RP501R in Übereinstimmung mit den grundlegenden Anforderungen und den übrigen einschlägigen Bestimmungen der Richtlinie 1999/5/EG befindet. |
| <b>Estonian</b>   | Käesolevaga kinnitab Roland Corporation seadme RP501R vastavust direktiivi 1999/5/EÜ põhinõuetele ja nimetatud direktiivist tulenevatele teistele asjakohastele sätetele.                           |
| <b>Greek</b>      | ΜΕ ΤΗΝ ΠΑΡΟΥΣΑ Roland Corporation ΔΗΛΩΝΕΙ ΟΤΙ RP501R ΣΥΜΜΟΡΦΩΝΕΤΑΙ ΠΡΟΣ ΤΙΣ ΟΥΣΙΩΔΕΙΣ ΑΠΑΙΤΗΣΕΙΣ ΚΑΙ ΤΙΣ ΛΟΙΠΕΣ ΣΧΕΤΙΚΕΣ ΔΙΑΤΑΞΕΙΣ ΤΗΣ ΟΔΗΓΙΑΣ 1999/5/ΕΚ  |
| <b>Spanish</b>    | Por la presente, Roland Corporation, declara que este RP501R cumple con los requisitos esenciales y otras exigencias relevantes de la Directiva 2014/53/EU.   |
| <b>French</b>     | Par la présente, Roland Corporation déclare que l'appareil RP501R est conforme aux exigences essentielles et aux autres dispositions pertinentes de la directive 1999/5/CE.                         |
| <b>Italian</b>    | Con la presente Roland Corporation dichiara che questo RP501R è conforme ai requisiti essenziali ed alle altre disposizioni pertinenti stabilite dalla direttiva 1999/5/CE.                         |
| <b>Latvian</b>    | Ar šo Roland Corporation deklarē, ka RP501R atbilst Direktīvas 1999/5/EK būtiskajām prasībām un citiem ar to saistītajiem noteikumiem.  |
| <b>Lithuanian</b> | Šiuo Roland Corporation deklaruoja, kad šis RP501R atitinka esminius reikalavimus ir kitas 1999/5/EB Direktyvos nuostatas   |
| <b>Hungarian</b>  | A Roland Corporation ezzennel kijelenti, hogy a RP501R típusú berendezés teljesíti az alapvető követelményeket és más 1999/5/EK irányelvben meghatározott vonatkozó rendelkezéseket.                |
| <b>Dutch</b>      | Hierbij verklaart Roland Corporation dat het toestel RP501R in overeenstemming is met de essentiële eisen en de andere relevante bepalingen van richtlijn 1999/5/EG.                                |
| <b>Polish</b>     | Niniejszym Roland Corporation deklaruje że RP501R jest zgodny z zasadniczymi wymaganiami i innymi właściwymi postanowieniami Dyrektywy 2014/53/EU.  |
| <b>Portuguese</b> | Eu, Roland Corporation, declaro que o RP501R cumpre os requisitos essenciais e outras provisões relevantes da Directiva 2014/53/EU.   |
| <b>Romanian</b>   | Prin prezenta, Roland Corporation, declară că aparatul RP501R este în conformitate cu cerințele esențiale și cu alte prevederi pertinente ale Directivei 1999/5/CE.                                 |
| <b>Slovak</b>     | Roland Corporation týmto vyhlasuje, že RP501R spĺňa základné požiadavky a všetky príslušné ustanovenia Smernice 1999/5/ES.  |
| <b>Slovenian</b>  | Roland Corporation izjavlja, da je ta RP501R v skladu z bistvenimi zahtevami in drugimi relevantnimi določili direktive 1999/5/ES.  |
| <b>Finish</b>     | Roland Corporation vakuuttaa täten että RP501R tyyppinen laite on direktiivin 1999/5/EY oleellisten vaatimusten ja sitä koskevien direktiivin muiden ehtojen mukainen.                              |
| <b>Swedish</b>    | Härmed intygar Roland Corporation att denna RP501R står i överensstämmelse med de väsentliga egenskapskrav och övriga relevanta bestämmelser som framgår av direktiv 1999/5/EG.                     |

The Declaration of Conformity may be consulted in Downloads menu of this product at [www.roland.com](http://www.roland.com).

This unit has an RF transmitter(s) with the following specification.

- Operating frequency: 2400–2483.5 MHz
- Maximum RF transmit power: 2.5 mW

 Roland

